

## CHARGRILL SERIE 750 CABINET 600 2018

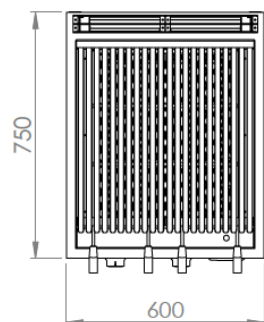
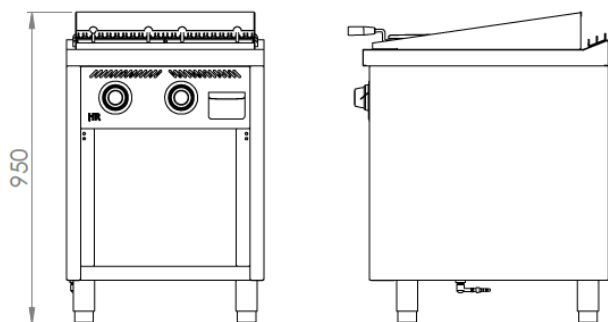

GENERAL FEATURES	
Brand	FAINCA HR
Family	CHARGRILL
Model	B7506E
Main Material	Stainless Steel AISI-304
Control device	YES
Control type	KNOB
Type of heating	GAS
Selection of the degree of temperature	2 positions
Useful Area (cm <sup>2</sup> )	3000
Removable Grills	YES
Height adjustable grills	YES
Volcanic stone	YES
Cleaning	Stainless Steel
Frame material	Stainless Steel
Heat resistant housing	YES
Fat drip tray	2

PACKAGING	
EAN Code	8437006769150
Standard pcs per packing unit / carton	1
Net weight (kg)	70
Gross weight (kg)	80
Number of pcs/pallet as standard	1

TECHNICAL DATA	
Certifications of approval	CE
Max. Power G. Butane / Propane (kW)	17,52
Max. Power Natural Gas (kW)	17,52
Number of burners	2
Power per burner (kW)	8,76
Safety device	YES - THERMOCOUPLE
Ignition pilot	NO
Piezoelectric	NO

DIMENSIONS OF THE APPLIANCE	
Device dimensions (width, depth, height) (mm)	600x750x950h
Measures of the product packed (mm)	660x810x1140h