

## CHARGRILL SERIE 750 CABINET 800 2018

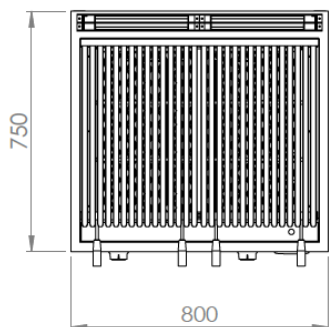
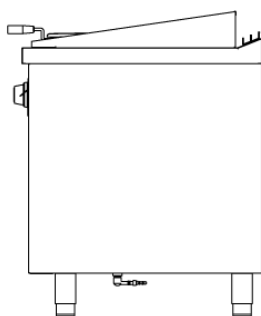
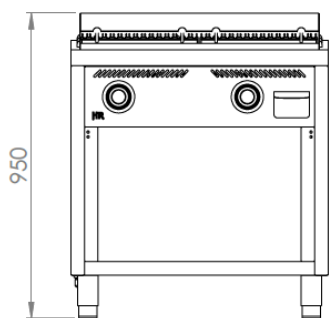
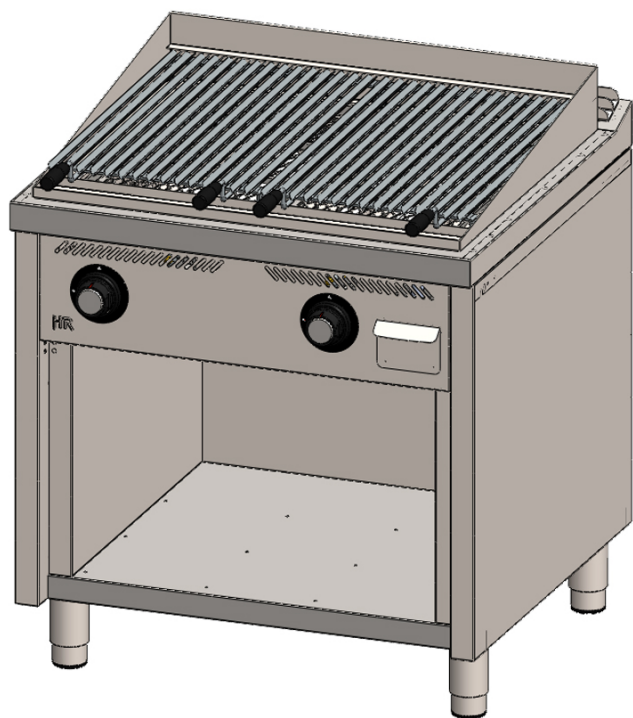

### GENERAL FEATURES

Brand	FAINCA HR
Family	CHARGRILL
Model	B7508E
Main Material	Stainless Steel AISI-304
Control device	YES
Control type	KNOB
Type of heating	GAS
Selection of the degree of temperature	2 positions
Useful Area (cm <sup>2</sup> )	4113
Removable Grills	YES
Height adjustable grills	YES
Volcanic stone	YES
Cleaning	Stainless Steel
Frame material	Stainless Steel
Heat resistant housing	YES
Fat drip tray	2

### PACKAGING

EAN Code	843700676917
Standard pcs per packing unit / carton	1
Net weight (kg)	93
Gross weight (kg)	103
Number of pcs/pallet as standard	1

### TECHNICAL DATA

Certifications of approval	CE
Max. Power G. Butane / Propane (kW)	26,28
Max. Power Natural Gas (kW)	26,28
Number of burners	3
Power per burner (kW)	8,76
Safety device	SI - TERMOPAR
Ignition pilot	NO
Piezoelectric	NO

### DIMENSIONS OF THE APPLIANCE

Device dimensions (width, depth, height) (mm)	800x750x950h
Measures of the product packed (mm)	860x810x1140h