

6L+6L FOSTER FRYER / ECONOMIC SERIES 2018

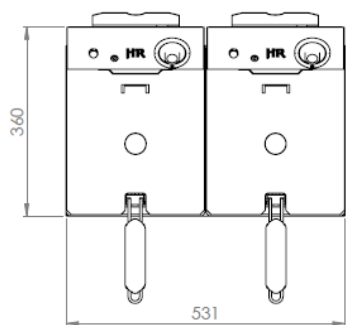
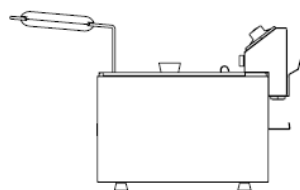
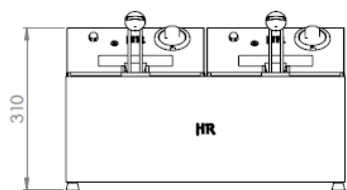
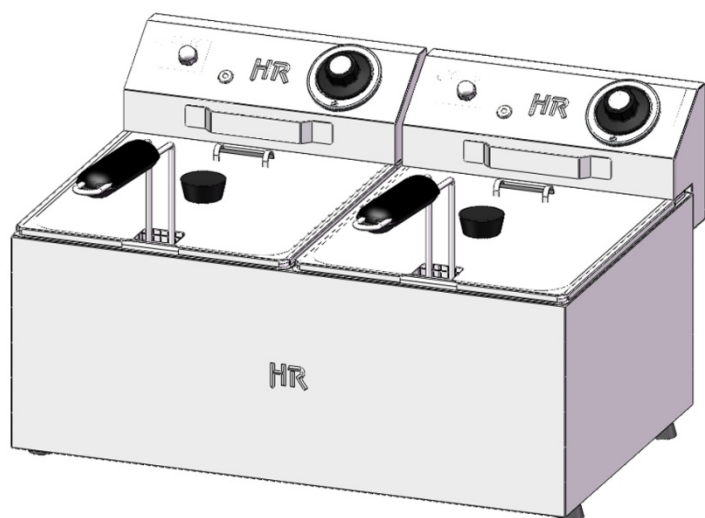

GENERAL SPECIFICATIONS	
Brand	FAINCA HR
Family	FRYERS
Model	FD6L6LF
Raw material	Stainless Steel AISI-304
Length of the power cable (m)	1,25
Oil capacity (L)	2x (6 L)
Material of the tanks	Stainless Steel
Material of the baskets	Steel
Faucet cap locking	No
Window / Viewfinder	No
Filter	No
Temperature selection	60°C to 190°C
Power Indicator	NO
Operation indicator	YES
Fault indicator	NO
Control Security Type	Temperature
Safety device	Thermal protection
Cable retractor	No
Type of plug	Grounding
Country of origin	SPAIN

PACKAGE DETAILS	
EAN Code	8437006768078
Standard pcs per packing unit / carton	1
Number of pcs/pallet as standard	14
Net weight (kg)	12
Gross weight (kg)	13

TECHNICAL DATA	
Type certification	CE
Connection power (kW)	2x (4,2 kW)
Voltage (V)	230
Frequency (Hz)	50-60

DIMENSIONS OF THE APPLIANCE	
Device dimensions (width, depth, height) (mm)	265x360x310h
Measures of the product packed (mm)	325x420x380h
Interior dimensions of the basket (width, depth, height) (mm)	210x210x100h