

GAS RANGE 2 BURNERS 750 CABINET 2018

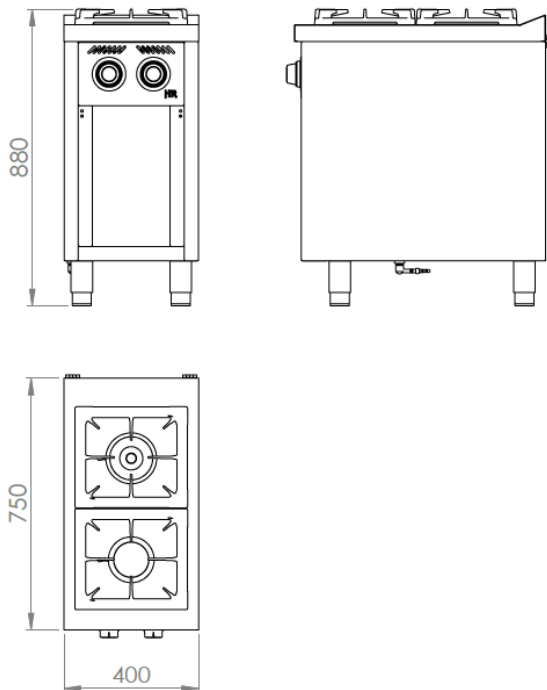
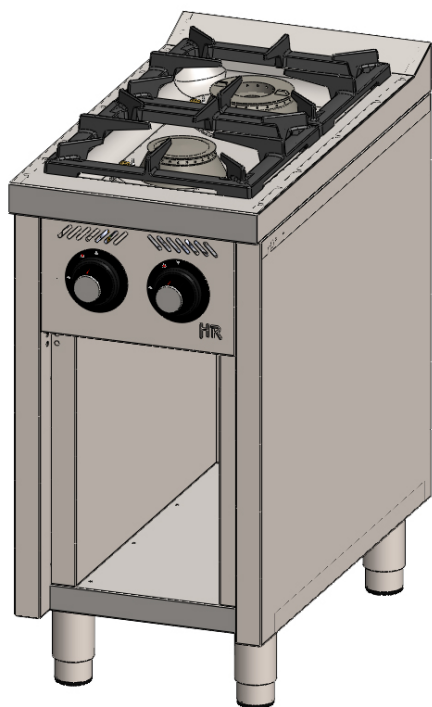

GENERAL FEATURES	
Brand	FAINCA HR
Family	GAS RANGE
Model	C2F750E
Countertop Lifting System	Incorporated
Main Material	Stainless steel AISI-304
Control device	YES
Control type	KNOB
Type of heating	GAS
Selection of the degree of temperature	2 positions-adjustable
Removable grills	YES
Max. Oven power G. Butane/Propane (kW)	No oven
Max. Oven power Natural Gas (kW)	No oven
Useful capacity of the oven (L)	No oven

PACKAGING	
EAN Code	8437006768429
Standard pcs per packing unit / carton	1
Net weight (kg)	48
Gross weight (kg)	63
Number of pcs/pallet as standard	1

TECHNICAL DATA	
Certifications of approval	CE
Max. Power G. Butane / Propane (kW)	11,2
Max. Power Natural Gas (kW)	15,3
Number of burners	2
Thermostatic oven valve	NO
Safety device	YES - THERMOCOUPLE
Ignition pilot	YES
Piezoelectric	NO

DIMENSIONS OF THE APPLIANCE	
Device dimensions (width, depth, height) (mm)	400x750x880h
Measures of the product packed (mm)	460x810x1070h
Interior dimensions of the oven (width, depth, height) (mm)	No Oven



BURNER POWER (kW)	G. Butane/Propane (G-30/G-31)	6,5	4,7
	Natural gas (G-20)	8,5	6,8
	Units	1	1