

ELECTRIC COOKER 4 PLATES S/750 TOP 2019

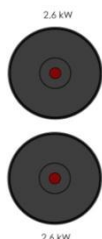
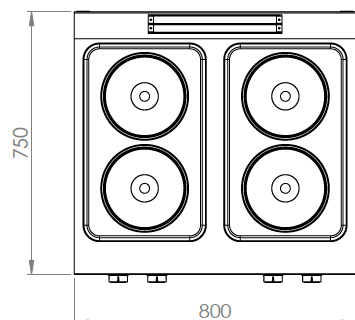
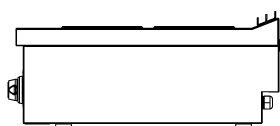
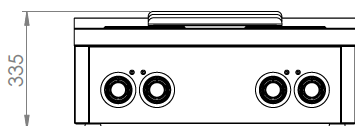

GENERAL FEATURES	
Brand	FAINCA HR
Family	COOKERS
Model	CE4P750S
Main Material	STAINLESS STEEL AISI 304
Control device	YES
Type of control / Quantity	KNOB / 4
Type of Heating	ELECTRIC RESISTANCE
Selection of Temperature degree in Cookers	ADJUSTABLE / 6 POS.
Selection of Temp.degree in Oven/ Range (°C)	/
Plates	
Quantity	4
Diameter (mm)	4x220
Removable grills in cookers	Does not incorporate
Oven	Does not incorporate
Useful Capacity of the Oven (L)	/
Dimensions (height, width, depth) (mm)	/
Material	/
Maximum Oven Power (kW)	/
Upper Line Power (Grill) (kW)	/
Power in the lower line (kW)	/
Anti-roll grill	/
Lower tray	/
Fiberglass Insulating Seal (oven)	/
Cleaning	STAINLESS STEEL
Heat Resistant Housing	YES
Power indicator	YES
Operation indicator	NO

PACKAGING	
EAN Code	8437006795326
Standard pcs per packing unit / carton	1
Number of pcs/pallet as standard	1
Net weight (kg)	49
Gross weight (kg)	59

TECHNICAL DATA	
Certifications of approval	CE
Max. Power (kW)	10,4
Voltage (V)	380 / 400
Control Security Type	TEMP.
Security device	Internal limiter
Security device in Oven	/
Connections	
Electric/ Position	Terminal block/ Rear

DIMENSIONS OF THE APPLIANCE	
Device dimensions (width, depth, height) (mm)	800x750x335h
Measures of the product packed (mm)	880x830x470h