

ELECTRIC FRY-TOP S/600 CABINET 600 2018

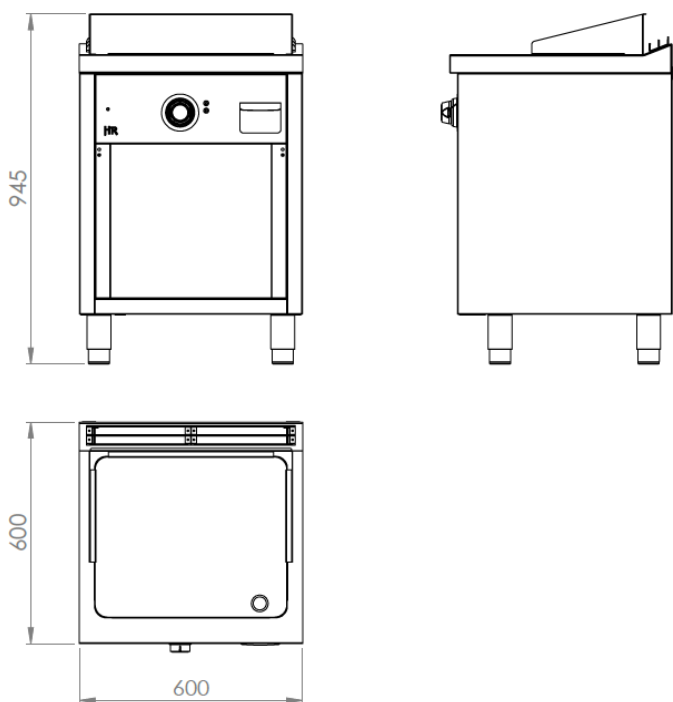
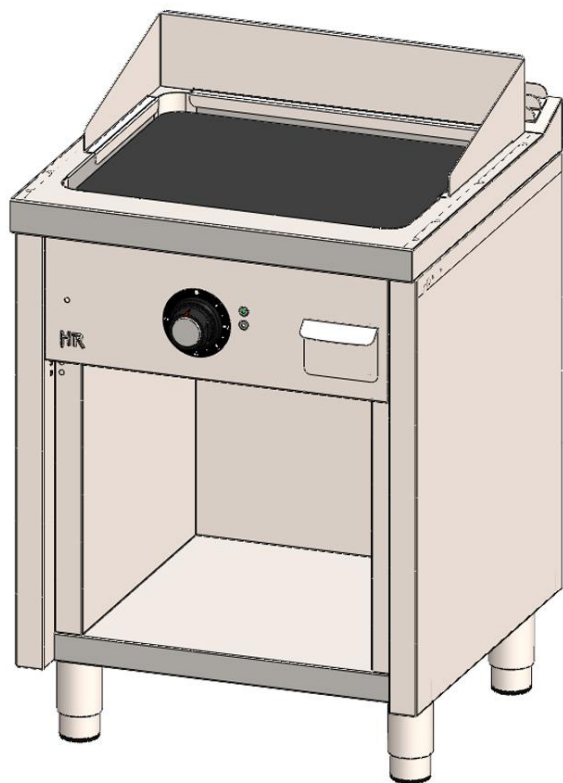

GENERAL FEATURES

Brand	FAINCA HR
Family	FRYTOPS
Model	FTE6006E
Main Material	Stainless Steel AISI-304
Control device	YES
Control type	KNOB
Quantity (Zones)	1
Type of heating	ELECTRIC RESISTANCE
Selection of the degree of temperature	ADJUSTABLE
Temperature range (°C)	50-300 °C
Type of griddle plate	RECTIFIED
Dimensions	515mm x 432mm
Useful Area	2220 cm ²
Griddle plate thickness(mm)	15
Cleaning	Stainless Steel
Heat Resistant Housing	YES
Fat drip drawer	YES
Capacity	1.8 L

PACKAGING

EAN Code	8437006793278
Standard pcs per packing unit / carton	1
Net weight (kg)	73
Gross weight (kg)	88
Number of pcs/pallet as standard	1

TECHNICAL DATA

Certifications of approval	CE
Max. Power (kW)	6,3
Electric tension	380V/400V
Connection type	Internal Power Strip
Location	Rear
Connection cable	Does not incorporate
Safety device	YES - THERMOSTAT
Power indicator	YES
Operation indicator	YES

DIMENSIONS OF THE APPLIANCE

Device dimensions (width, depth, height) (mm)	600x600x945h
Measures of the product packed (mm)	660x660x1135h