

ELECTRIC FRY-TOP S/600 CABINET 800 2018

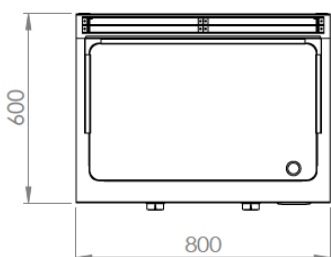
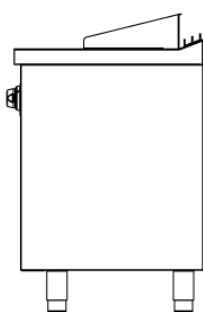
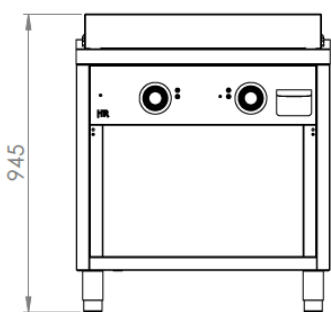
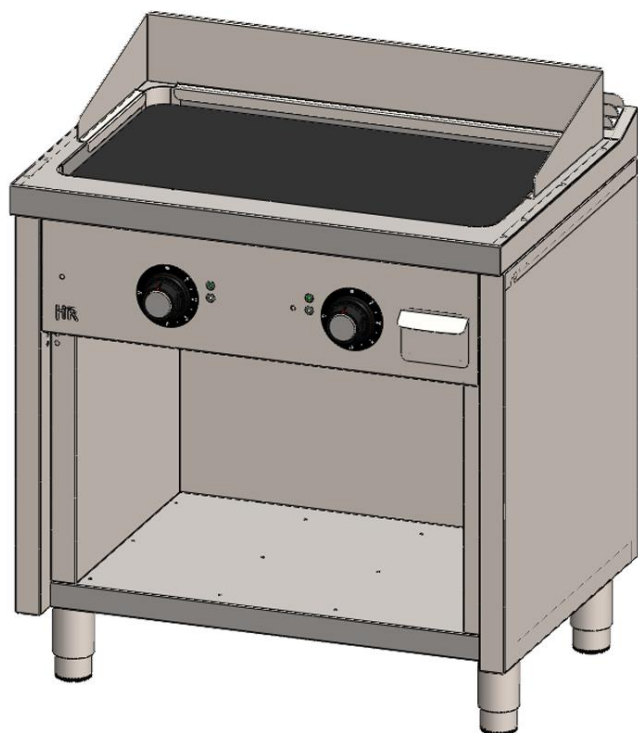

GENERAL FEATURES	
Brand	FAINCA HR
Family	FRYTOPS
Model	FTE6008E
Main Material	Stainless Steel AISI-304
Control device	YES
Control type	KNOB
Quantity (Zones)	2
Type of heating	ELECTRIC RESISTANCE
Selection of the degree of temperature	ADJUSTABLE
Temperature range (°C)	50-300 °C
Type of griddle plate	RECTIFIED
Dimensions	715mm x 432mm
Useful Area	3085 cm ²
Griddle plate thickness(mm)	15
Cleaning	Stainless Steel
Heat Resistant Housing	YES
Fat drip drawer	YES
Capacity	1.8 L

PACKAGING	
EAN Code	8437006794244
Standard pcs per packing unit / carton	1
Net weight (kg)	90
Gross weight (kg)	105
Number of pcs/pallet as standard	1

TECHNICAL DATA	
Certifications of approval	CE
Max. Power (kW)	7,8
Electric tension	380V/400V
Connection type	Internal Power Strip
Location	Rear
Connection cable	Does not incorporate
Safety device	YES - THERMOSTAT
Power indicator	YES
Operation indicator	YES

DIMENSIONS OF THE APPLIANCE	
Device dimensions (width, depth, height) (mm)	800x600x945h
Measures of the product packed (mm)	860x660x1135h